

(No Model.)

W. BIRSS.
STONE CUTTING MACHINE.

No. 252,172.

Patented Jan. 10, 1882.

Fig. 1.

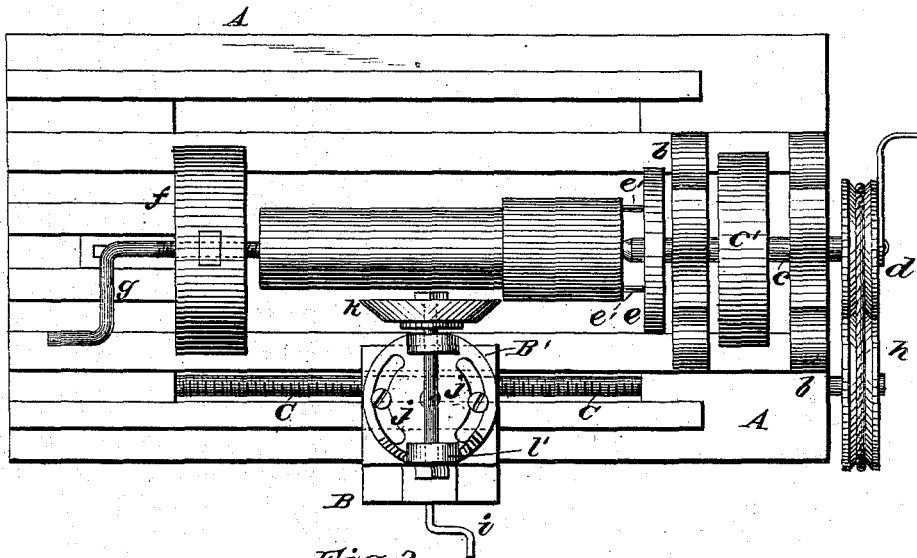

Fig. 2.

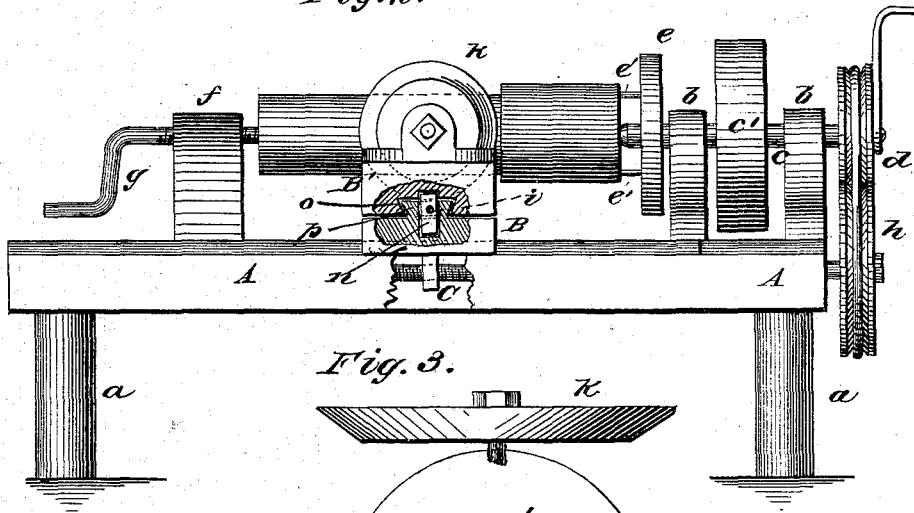
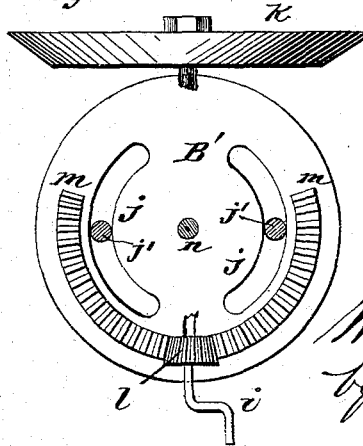

Fig. 3.



WITNESSES

Adm. G. Dieterich.
P. B. Dieterich.

William Birss.
INVENTOR
by Louis Bagger & Co.
his Attorneys

UNITED STATES PATENT OFFICE.

WILLIAM BIRSS, OF LONG COVE, TENANT'S HARBOR, MAINE.

STONE-CUTTING MACHINE.

SPECIFICATION forming part of Letters Patent No. 252,172, dated January 10, 1882.

Application filed July 22, 1881. (No model.)

To all whom it may concern:

Be it known that I, WILLIAM BIRSS, of Long Cove, Tenant's Harbor, in the county of Knox and State of Maine, have invented certain new and useful Improvements in Stone-Cutting Machines; and I do hereby declare that the following is a full, clear, and exact description of the invention, which will enable others skilled in the art to which it appertains to make and use the same, reference being had to the accompanying drawings, which form a part of this specification, and in which—

Figure 1 is a plan view of my improved stone-cutting machine. Fig. 2 is a side view, partly broken away, showing the lathe or cutter operating screw; and Fig. 3 is a detail plan view, on an enlarged scale, of the top of the sliding and adjustable carriage which carries the rotary cutter.

This invention relates to improvements in stone-cutting machines, particularly for cutting round or cylindrical stone-surfaces; and it consists in certain details of construction and operation of parts, substantially as hereinafter more fully set forth and claimed.

Referring to the accompanying drawings, A is a bed-frame, preferably supported upon legs *a a*. Journaled in bearings *b b*, fastened at one end of the frame A, is a shaft, *c*, having a driving-pulley, *c'*, between said bearings, a second pulley, *d*, at its outer end, and a disk or plate, *e*, at its inner end, having facial pins or studs *e'*, which fit into cavities in the end of the stone to be operated upon and assist to hold it. At the opposite end of the frame A is a sliding block, *f*, having feet adapted to fit into and slide in grooves in that end of the frame which is provided with a hand-crank screw, *g*, adapted to bear in a cavity in that end of the stone or block of granite to effect the holding thereof. This block, it will therefore be seen, can be moved up to and away from the stone or block, as may be desired, in adjusting it in position to be cut and removing it after the completion of the cutting operation.

B is a carriage, which is adapted to travel by means of and upon the screw-rod C, extending the entire length of the frame and parallel with the line or plane of cutting the stone. It is driven by a pulley, *h*, at one end and a belt encompassing the latter and the pulley *d* upon

the shaft *c*. The upper part of this carriage, B', is capable of having a motion toward and from the work or at right angles to the plane of cutting the stone, to permit of the adjustment of the tool or cutter, accordingly as occasion may require. To effect this adjustment, a hand-screw, *i*, engaging a female screw-threaded eye or tube in the under side of the slide B' of the carriage B, is employed.

It will be observed that the top part, B', of the carriage B is of circular shape and provided with two segmental slots, *j j*, through which project studs or guide-pins *j' j'*, affixed in the carriage-block B, upon which the circular top is pivoted by a central pintle, *n*. To relieve the latter from strain the under side of the top part, B', has a central dovetailed recess, *o*, of circular shape, which fits upon a projecting stud or button, *p*, of corresponding shape, forming part of the carriage B, thus permitting of ready rotary adjustment of the top part, while at the same time relieving the central pintle, *n*, from strain, and also preventing the top from coming off of the bottom part, B.

The shaft *i* has a small pinion, *l*, covered by a box or casing, *l'*, which engages with a cogged section, *m*, upon the top of B' for effecting the rotary adjustment of said part with its cutter *k*.

It will be observed that this machine is adapted to cut cylindrical or round surfaces upon stone or blocks of granite, such as columns, vases, urns, &c.

Having thus fully described my invention, I claim and desire to secure by Letters Patent of the United States—

In a machine for cutting or dressing stone, the combination of the sliding carriage B, having central dovetailed button, *p*, and guide-studs *j' j'* on opposite sides of said button, pintle *n*, and circular top part, B', having segmental slots *j j*, and central circular dovetailed recess, *o*, as shown and described, for the purpose set forth.

In testimony that I claim the foregoing as my own I have hereunto affixed my signature in presence of two witnesses.

WILLIAM BIRSS.

Witnesses:

JOHN H. LONG,
HENRY F. KELLOCH.